

SK-Tonneau Cover Installation Instructions (TUNDRA)

PARTS LIST:

Part NO.	Description	QTY	Image	PART NO.	Description	QTY	Image
①	Cover Assembly	1		⑦	Buckle end	2	
②	Left rail	1		⑧	Clamp	10	
③	Right rail	1		⑨	Semicircle seal	3	
④	Bolt and knob unit	2		⑩	Bulkhead seal	1	
⑤	Knob bolt	2		⑪	Parts kit	4 Cross socket screw+10 Star socket screw M6_30+10 Star socket screw M6_10+Star wrench	
⑥	Square block	2		⑫	Drain hose and fastener	2	

SK-Tonneau Cover Installation Instructions (TUNDRA)

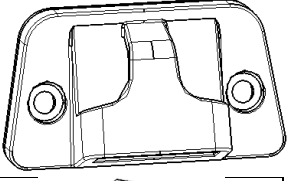
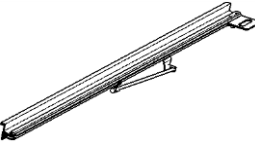
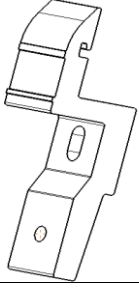
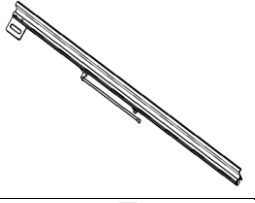
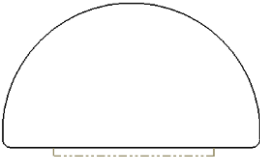
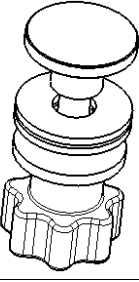
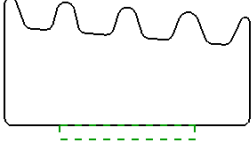
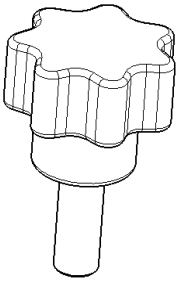
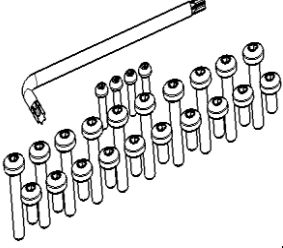
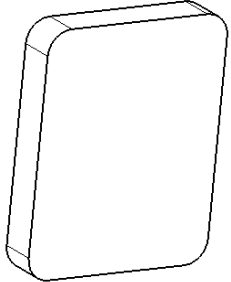
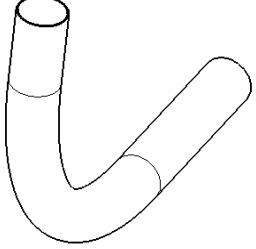
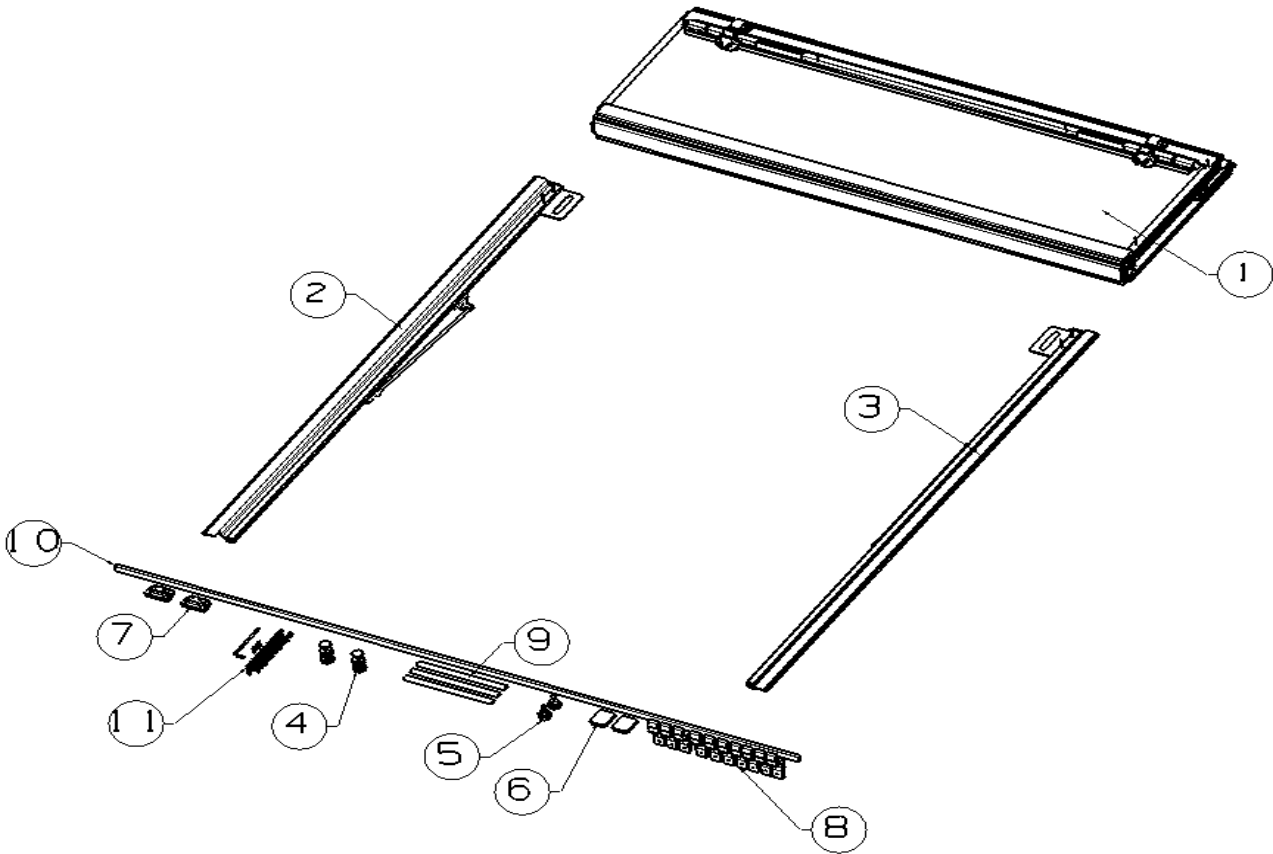

ASSEMBLY PROCEDURE:

FOAM SEAL INSTALL TO HEADER RAIL ENDS

TOOLS NEEDED:
T-30 Torx driver, 3/8" drive short extension, ratchet

1. Remove factory cab header rail
2. Use T-30 Torx driver to remove 5 fasteners securing header rail to front bulkhead below cab rear window
3. Peel backing paper off of foam seal and adhere to header rail endcaps
4. Reposition factory cab header rail on truck bed
5. Install and torque all mounting bolts to 7.5Nm (66.5 lbs-in)

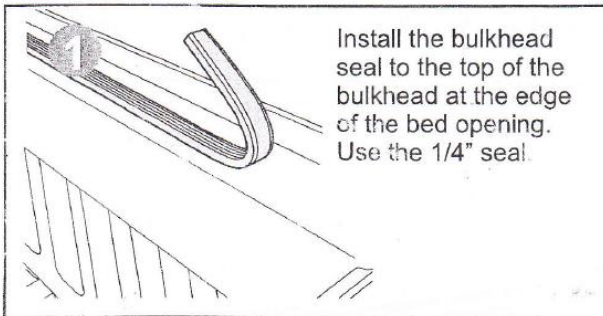
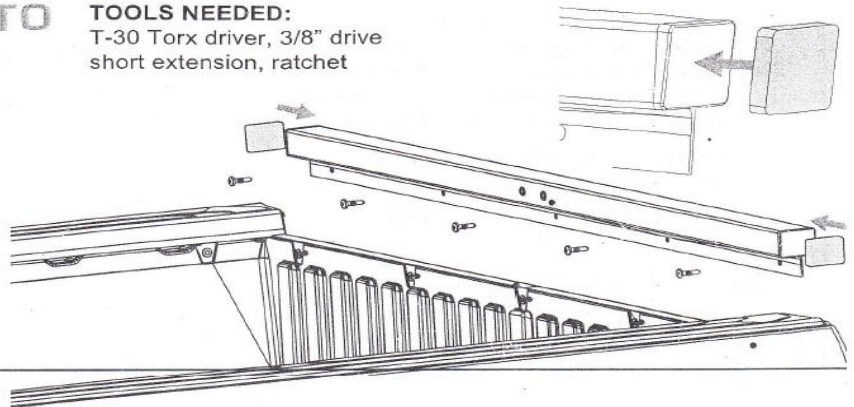

Install the bulkhead seal to the top of the bulkhead at the edge of the bed opening. Use the 1/4" seal.

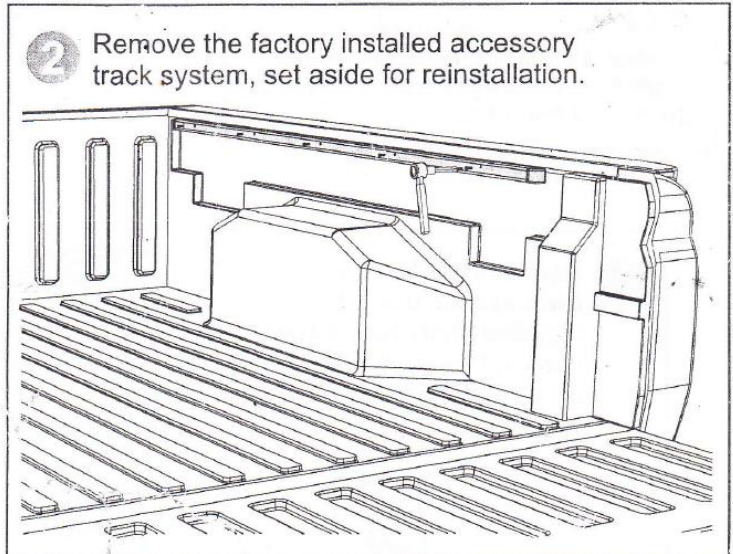

2 Remove the factory installed accessory track system, set aside for reinstallation.

Parts included:

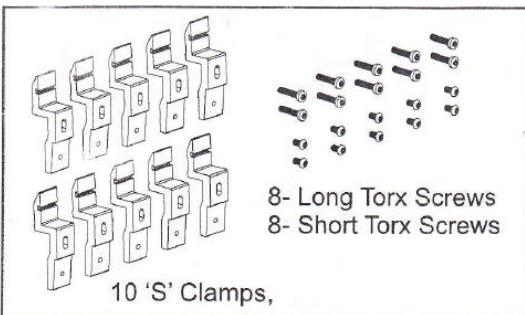

8- Long Torx Screws
8- Short Torx Screws

10 'S' Clamps,

SK-Tonneau Cover Installation Instructions (TUNDRA)

- 3 Slide the 'S' clamps into the corresponding slot in the supplied rail.

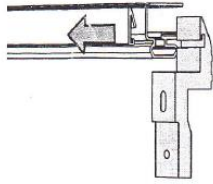

- 4 Align the 'S' clamps to match the spacing of the original factory track system mounting holes.

4- 'S' clamps for a 5 foot bed,
5- 'S' clamps for a 6 foot bed.

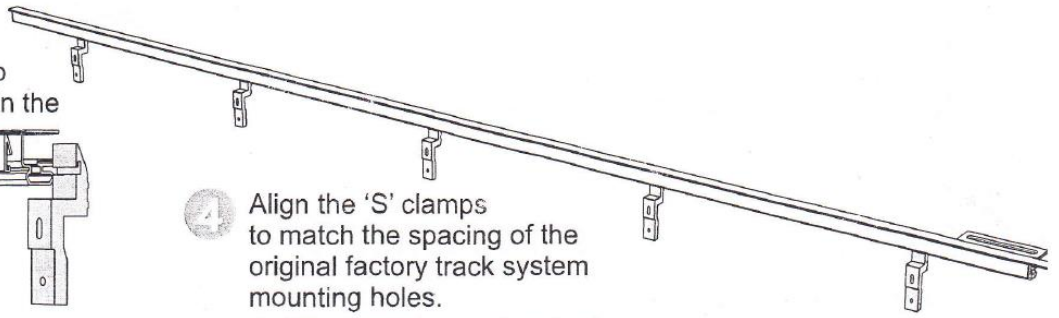

- 5 Mount the supplied rail into the original factory mounting holes using the supplied long Torx screws through the middle slot of the 'S' clamps.

Align the rail with the front/cab bulkhead, per Step 5A, tighten the screws.



5A

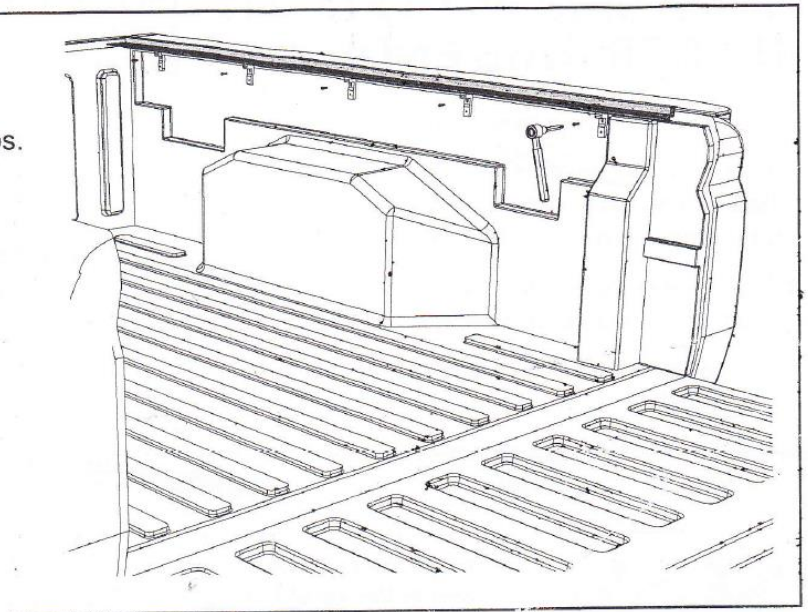
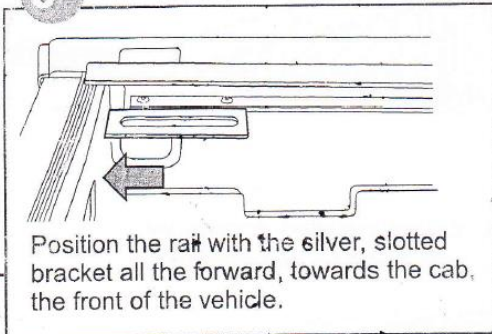

- 6 Remount the factory track system using the supplied short Torx screws into the threaded holes at the bottom of the 'S' clamps.

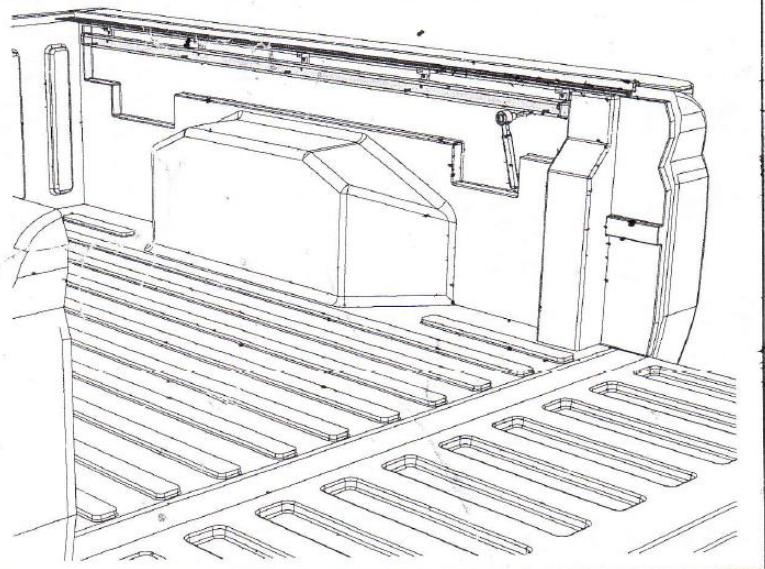
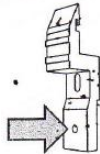

Return to standard Installation Sheet, Step 8.

SK-Tonneau Cover Installation Instructions (TUNDRA)

7

Place the rear clamp approx 6 inches from tailgate. Tighten all the clamps until snug. Then torque an additional 1/2 turn (approx 10 ft/lbs). Repeat steps 2-7 on opposite side.

8

9

Set the cover in the folded position on the SK1 rails towards the front of cab with the small panel forward.

11

The small panel faces forward, toward the cab and folds down over the silver brackets. The front panel must sit just inside the bulkhead rail with the seal resting on top of the rail. Fold the panel down and align it so it is setting squarely on the rails and align the mounting holes with the silver slotted brackets on the rails.

10 **IMPORTANT**

Before mounting the cover on truck, using a screwdriver install the two buckle ends into pre-drilled holes on the front header with the provided machine screws and threaded posts. **DO NOT** use a screw gun, securely tighten by hand only.

12

Install the three cab bumpers along the top edge of the cover where it meets the truck cab.

13

Insert the large flat bolt with the supplied rubber washer through the front panel and silver slotted bracket underneath. Repeat on other side.

SK-Tonneau Cover Installation Instructions (TUNDRA)

14

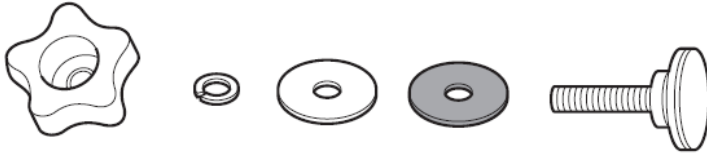

The large flat bolt goes down through the front panel on each side. Underneath the cover, the order of washers is as follows: rubber washer first, then large flat stainless washer, then the lock washer, and finally the 5 star finger knob as shown to the left.

15

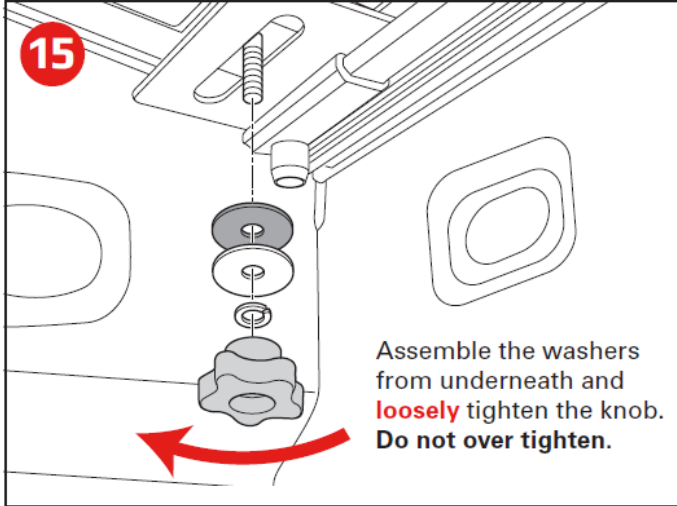

Assemble the washers from underneath and **loosely** tighten the knob. **Do not over tighten.**

16

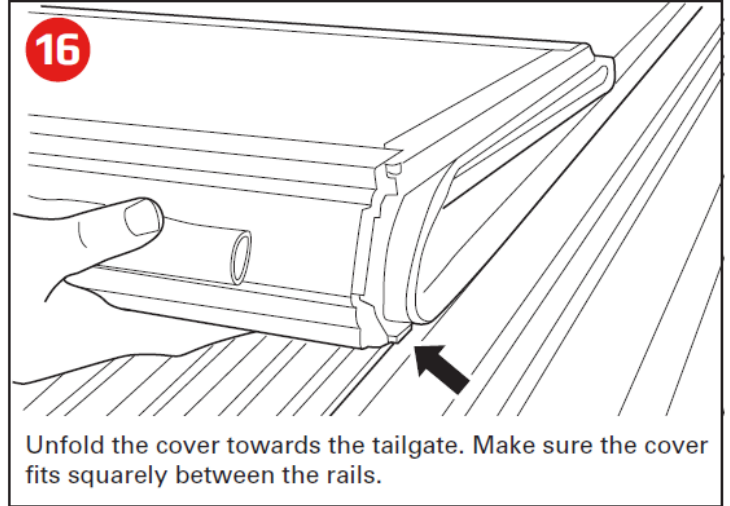

Unfold the cover towards the tailgate. Make sure the cover fits squarely between the rails.

17

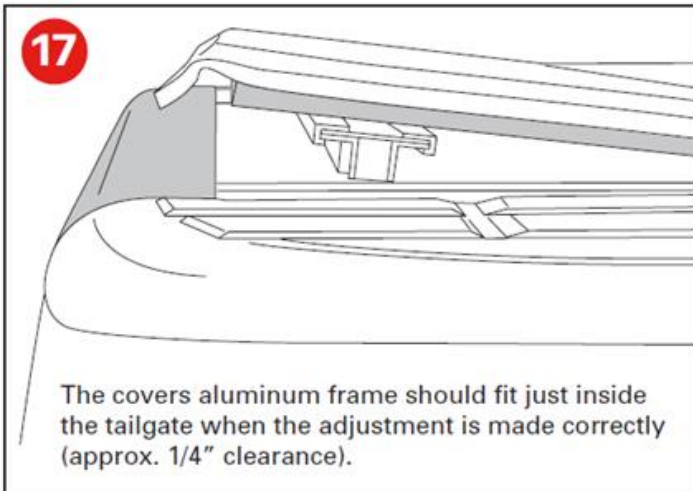

The covers aluminum frame should fit just inside the tailgate when the adjustment is made correctly (approx. 1/4" clearance).

18

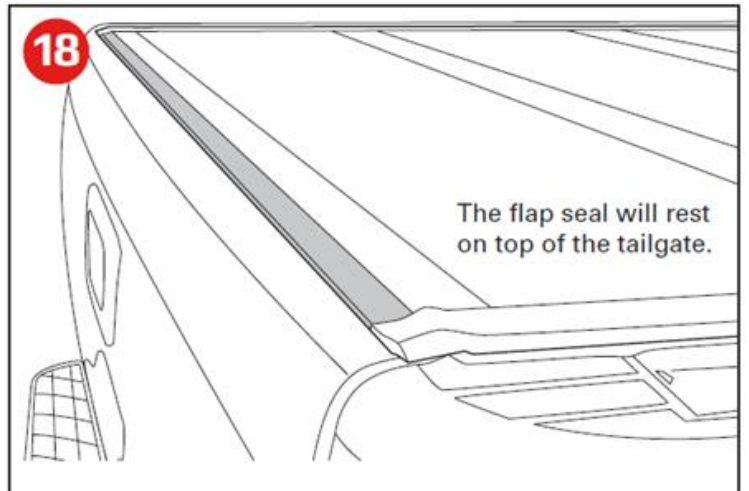

The flap seal will rest on top of the tailgate.

19

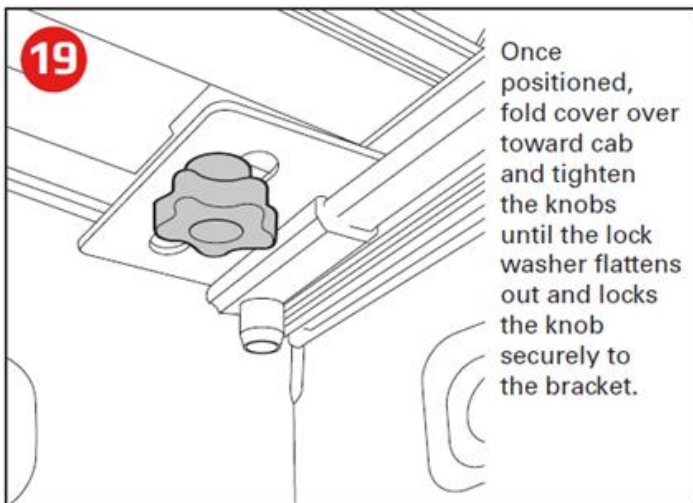

Once positioned, fold cover over toward cab and tighten the knobs until the lock washer flattens out and locks the knob securely to the bracket.

20

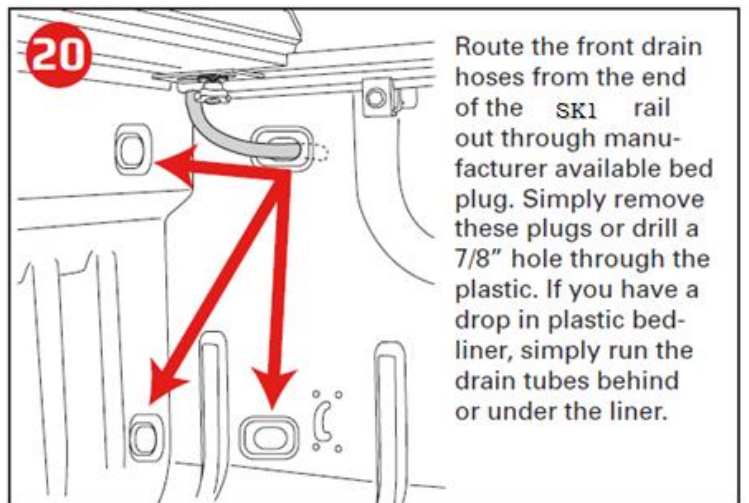

Route the front drain hoses from the end of the SK1 rail out through manufacturer available bed plug. Simply remove these plugs or drill a 7/8" hole through the plastic. If you have a drop in plastic bed-liner, simply run the drain tubes behind or under the liner.

SK-Tonneau Cover Installation Instructions (TUNDRA)

IMPORTANT NOTICE

While driving, cover must be completely flat and secure with all latches in the closed position OR completely folded up (all panels) and secured at the cab. **DO NOT DRIVE** with cover partially opened.

Tonneau Cover Positions While Operating Vehicle

Prior to vehicle operation, tonneau cover MUST be properly secured.

CLOSED POSITION

All panels must be closed and FULLY LATCHED to tonneau side rail. All panels must be flat and latches engaged.

FOLDED UP POSITION

To drive with your cover in the folded up position, simply make use of the tie down straps and buckles provided with your cover. Ensure BOTH buckle clips are fully inserted into the buckle ends located on the front header panel of the cover and adjust the straps to ensure the cover is secure during vehicle operation. The clips should be secured in the storage position, as shown in Figure 1, when not in use.

FLIPPED UP POSITION

A) Fold the cover open and lift it until its vertical or past 90 degrees towards your truck cab. Then release the prop rod that is attached to your rail. Fold the prop rod over and position it firmly against the vertical plate on the underside of your cover. Then slide the prop rod locks downwards and tighten the knobs to lock into position. Do this on both sides of the cover.

B) Your cover should be firmly in position with little to no movement once the prop rods are locked.

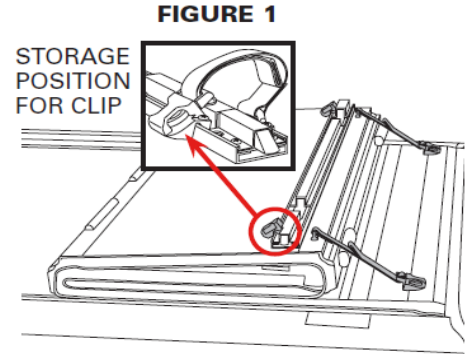
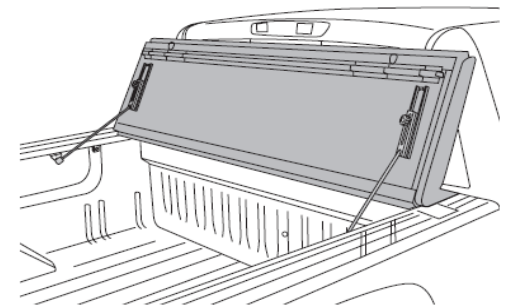
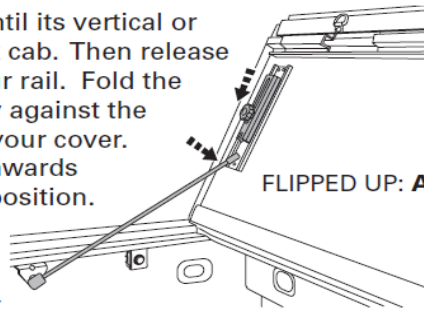

FOLDED UP POSITION