

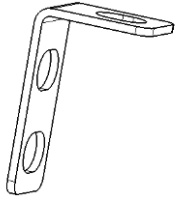

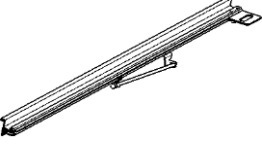
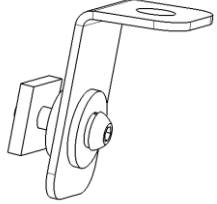

SK1-Tonneau Cover Universal Installation Instructions

PARTS LIST:

Part NO.	Description	QTY	Image	PART NO.	Description	QTY	Image
①	Cover Assembly	1		⑦	Front Bracket	2	
②	Left rail	1		⑧	Bracket set (Optional for utility track)	2	
③	Right rail	1		⑨	Semicircle seal	3	
④	Bolt and knob unit	2		⑩	Bulkhead seal	1	
⑤	Knob bolt	2		⑪	Socket head screw M4_15	4	
⑥	Buckle end	2			Drain hose and fastener	2	

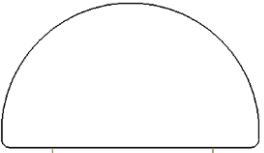
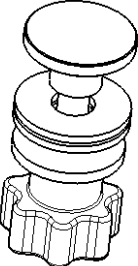
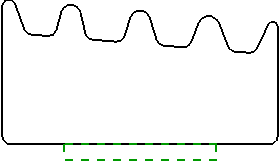
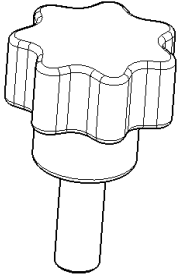
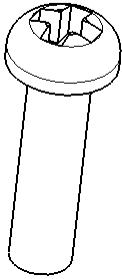
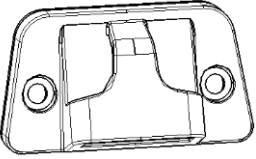
SK1-Tonneau Cover Universal Installation Instructions

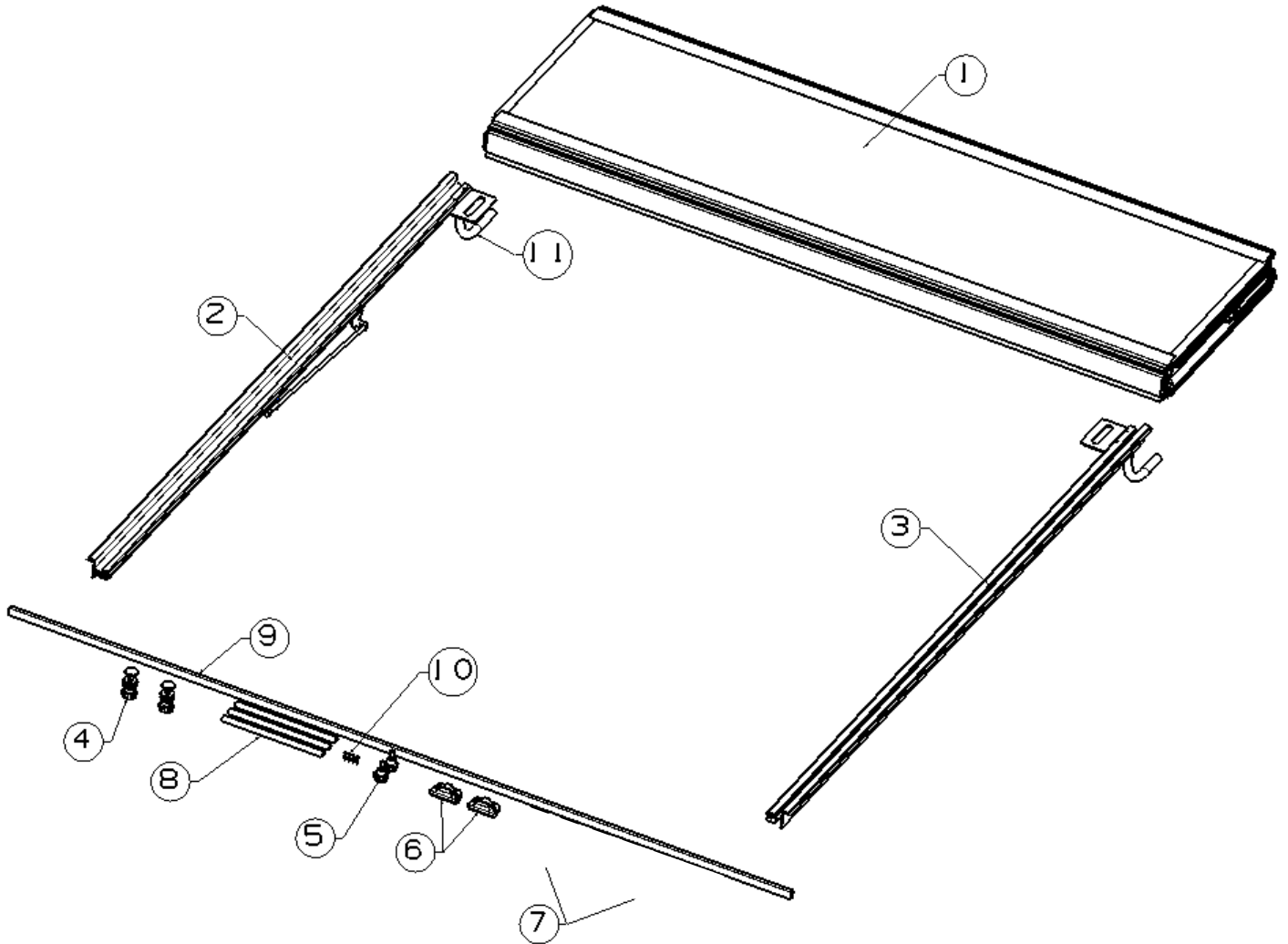

ASSEMBLY PROCEDURE:

1

If the truck does not have a drop in bedliner, install the cab/bulkhead seal (weather strip). Wipe painted surface with isopropyl alcohol before applying. If the truck has a drop in bedliner, no seal will be needed.

2

Close tailgate. Place SK1 rail on truck bed with silver bracket all the way forward and toward the center of bed as shown. Refer to enclosed **Spacing & Shimming Sheet** for more details. **Rails should be completely level.**

3

Install the rivet nut on front of the truck bed. Fasten the L-shaped front bracket with M8 bolt and washer, then connect it with the side rail.

NOTE: Some drop in liners may require trimming in the corners to fit the rail in the opening.

4

Optional, for those truck bed have OE utility track. You can slide in the bracket set. As picture shows .

SK1-Tonneau Cover Universal Installation Instructions

5

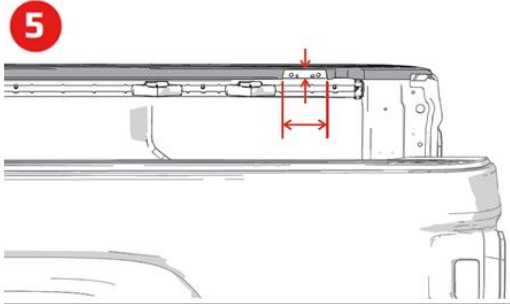

If the bed rail caps are not trimmed in the rear/ tailgate section, cut using the scribed lines as a guide to expose the area shown. Perform this operation on both sides of the truck bed.

6



Install the side rail on truck bed, put the M6 bolt & nut on rear part. As the picture shows, do not fasten the bolts.

7



For reference, after trimming the rear section on bed rail cap.

8

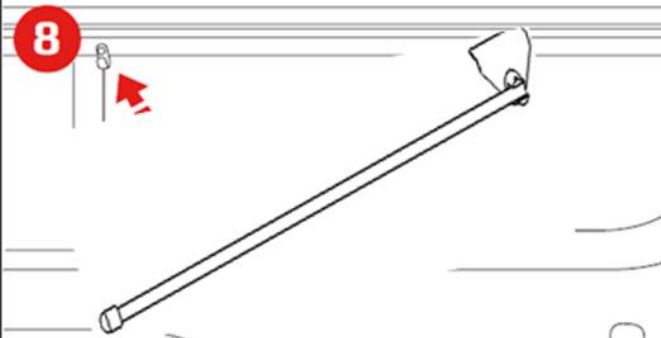

9

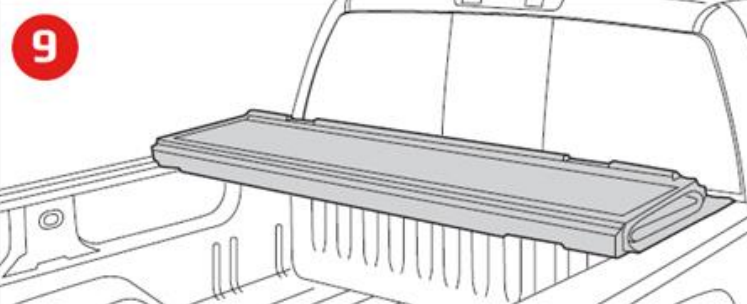

Set the cover in the folded position on the SK1 rails towards the front of cab with the small panel forward.

10 **IMPORTANT**

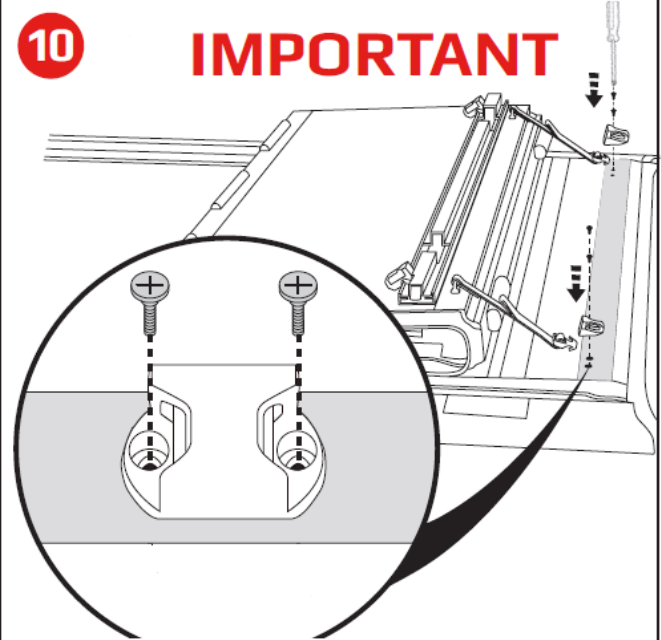

Before mounting the cover on truck, using a screwdriver install the two buckle ends into pre-drilled holes on the front header with the provided machine screws and threaded posts. **DO NOT** use a screw gun, securely tighten by hand only.

11

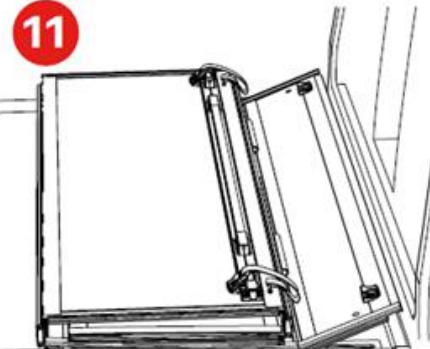

The small panel faces forward, toward the cab and folds down over the silver brackets. The front panel must sit just inside the bulkhead rail with the seal resting on top of the rail. Fold the panel down and align it so it is setting squarely on the rails and align the mounting holes with the silver slotted brackets on the rails.

12

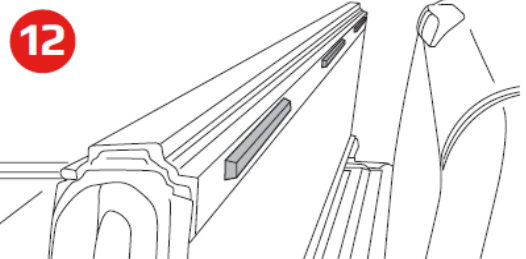

Install the three cab bumpers along the top edge of the cover where it meets the truck cab.

13

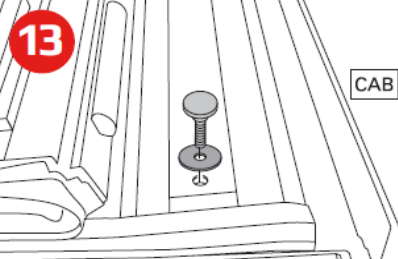

Insert the large flat bolt with the supplied rubber washer through the front panel and silver slotted bracket underneath. Repeat on other side.

SK1-Tonneau Cover Universal Installation Instructions

14

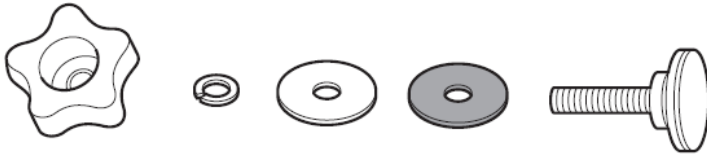

The large flat bolt goes down through the front panel on each side. Underneath the cover, the order of washers is as follows: rubber washer first, then large flat stainless washer, then the lock washer, and finally the 5 star finger knob as shown to the left.

15

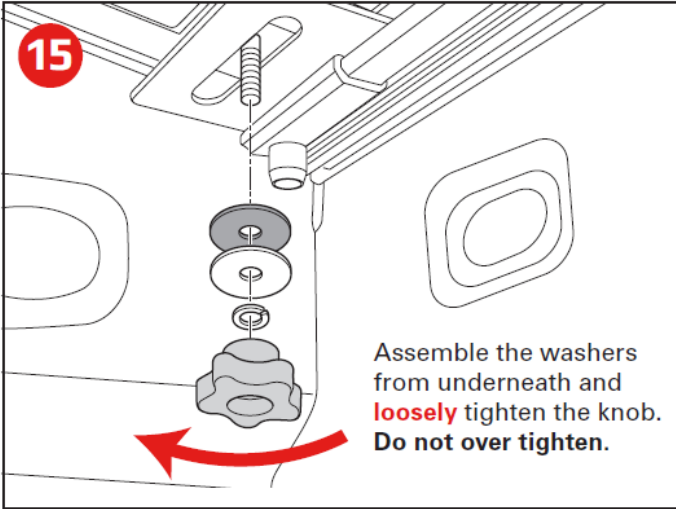

Assemble the washers from underneath and **loosely** tighten the knob. **Do not over tighten.**

16

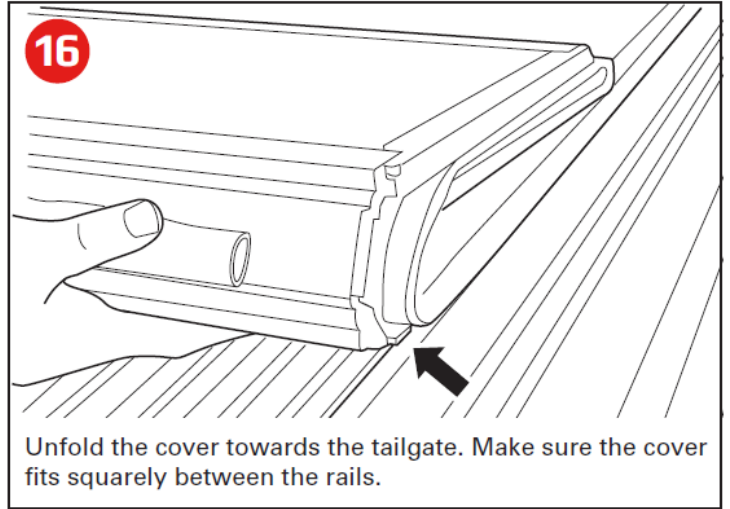

Unfold the cover towards the tailgate. Make sure the cover fits squarely between the rails.

17

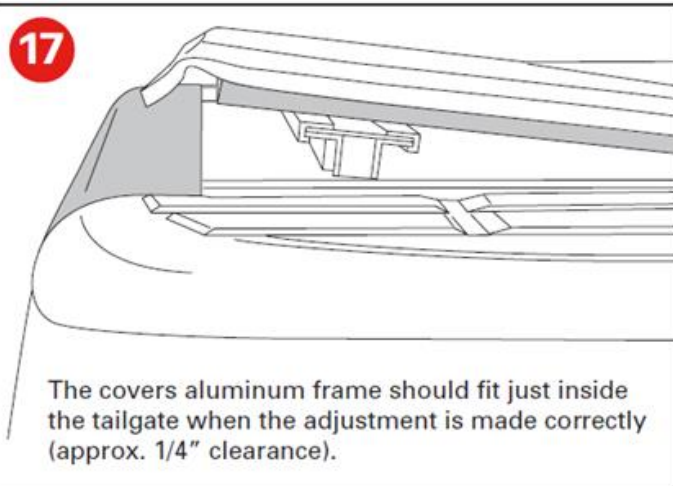

The covers aluminum frame should fit just inside the tailgate when the adjustment is made correctly (approx. 1/4" clearance).

18

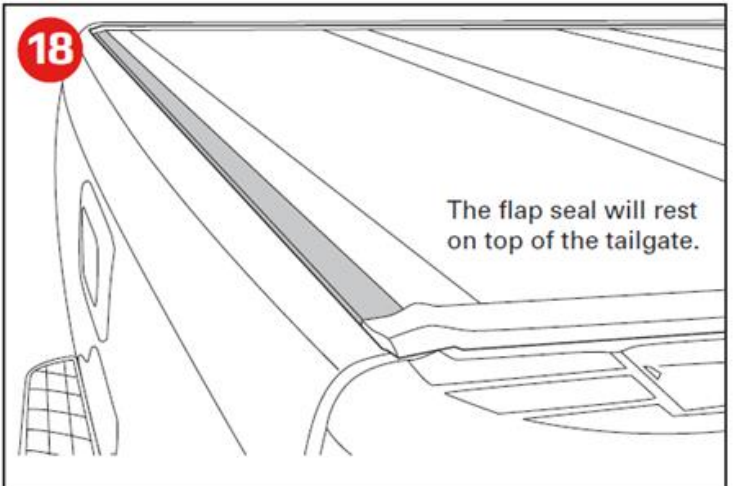

The flap seal will rest on top of the tailgate.

19

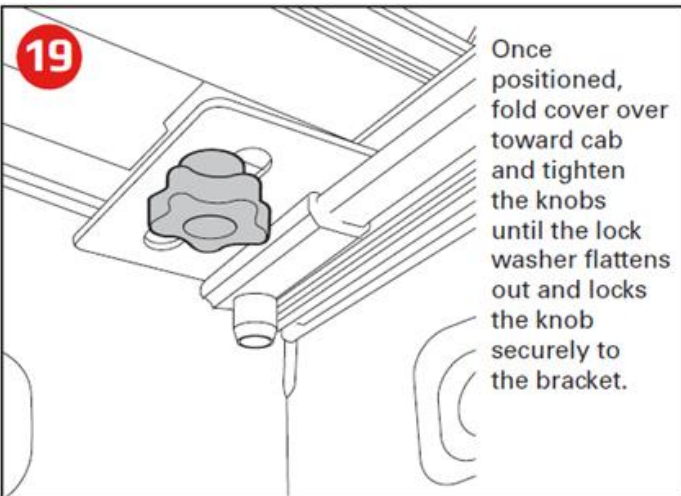

Once positioned, fold cover over toward cab and tighten the knobs until the lock washer flattens out and locks the knob securely to the bracket.

20

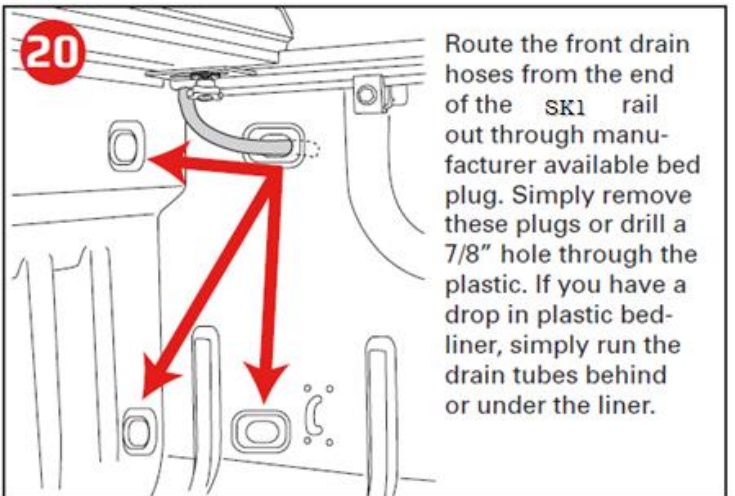

Route the front drain hoses from the end of the SK1 rail out through manufacturer available bed plug. Simply remove these plugs or drill a 7/8" hole through the plastic. If you have a drop in plastic bedliner, simply run the drain tubes behind or under the liner.

SK1-Tonneau Cover Universal Installation Instructions

IMPORTANT NOTICE

While driving, cover must be completely flat and secure with all latches in the closed position OR completely folded up (all panels) and secured at the cab. **DO NOT DRIVE** with cover partially opened.

Tonneau Cover Positions While Operating Vehicle

Prior to vehicle operation, tonneau cover MUST be properly secured.

CLOSED POSITION

All panels must be closed and FULLY LATCHED to tonneau side rail. All panels must be flat and latches engaged.

FOLDED UP POSITION

To drive with your cover in the folded up position, simply make use of the tie down straps and buckles provided with your cover. Ensure BOTH buckle clips are fully inserted into the buckle ends located on the front header panel of the cover and adjust the straps to ensure the cover is secure during vehicle operation. The clips should be secured in the storage position, as shown in Figure 1, when not in use.

FLIPPED UP POSITION

A) Fold the cover open and lift it until its vertical or past 90 degrees towards your truck cab. Then release the prop rod that is attached to your rail. Fold the prop rod over and position it firmly against the vertical plate on the underside of your cover. Then slide the prop rod locks downwards and tighten the knobs to lock into position. Do this on both sides of the cover.

B) Your cover should be firmly in position with little to no movement once the prop rods are locked.

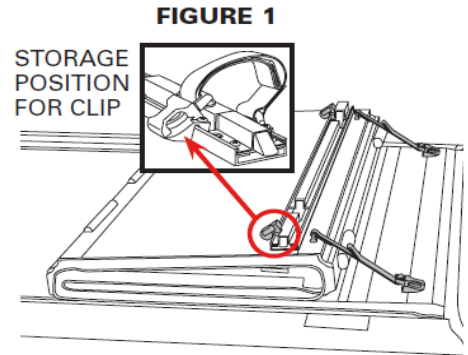
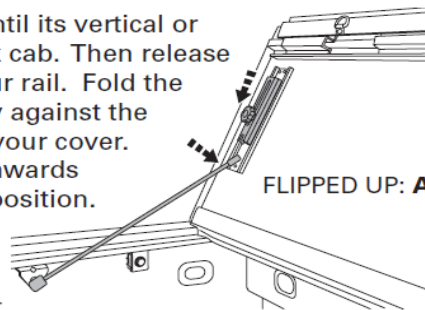
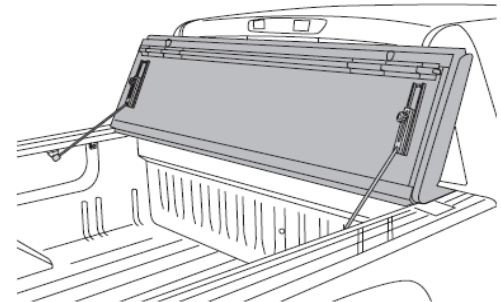

FIGURE 1
FOLDED UP POSITION



FLIPPED UP: A



FLIPPED UP: B

⚠️ IMPORTANT: READ FIRST ⚠️

Thank you for your recent purchase of a SK1 Tonneau Cover. Enclosed are both Spacer and Angle Shims to ensure a proper installation. Please refer to the guide on the back page to determine if your vehicle needs shims and where to position them.

Tech Tip 1 ANGLE SHIMS 3.36" x 0.63"

Installing the SK1 rails square to the truck bed rail is the key to a successful installation. Please note:

FIG 1: Some trucks have an indentation in the lower section of the bed rail (adding angle shims to the truck bed rail will be necessary). Position an angle shim at each clamp position.

FIG 2: Some trucks have a tapered clamping surface on the truck bed rail (adding angle shims to the truck bed rail will be necessary). Position an angle shim at each clamp position.

FIG 3: Some trucks have a square bed rail (no angle shims needed).

When needed, the angle shims are applied to the truck bed rail to prevent the SK1 rail from tilting when clamped in place. A squarely clamped rail ensures proper latching and sealing of the cover.

*SEE ILLUSTRATIONS AND REFER TO THE GUIDE ON THE BACK PAGE TO DETERMINE IF YOUR VEHICLE NEEDS ANGLE SHIMS AND PROPER PLACEMENT AS NEEDED.

